

BIN and STORAGE PILE DISCHARGERS



We Make Your Work Flow

Carrier[®]

Vibrating Equipment, Inc.

AND  **Vibrantics[®] Division**

Our Experience

Vibranetics has handled virtually every product stored in bulk in virtually every industry. Just a few examples . . .

- Radioactive waste
- Filter cake
- Diatomaceous earth
- Soda ash
- Kaolin clay
- Fly ash
- Oat flour
- Prepared foundry sand
- Returned foundry sand
- Pin chips
- Hogged wood waste
- Copper concentrate
- Sugar (powdered and granulated)
- Coal
- Lignite
- Petroleum coke
- Mill run
- Plastic powders
- Wood chips
- Hydrated lime
- Carbon black
- Tar sand
- Tobacco
- Detergents
- Bauxite

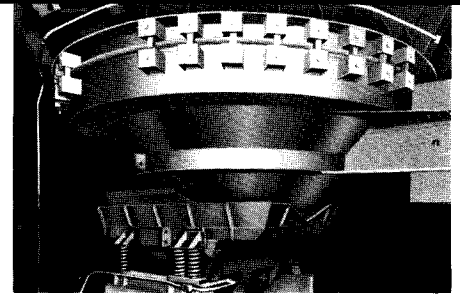

Bin Discharger: 15-ft in diameter discharging wood chips into a vibrating feeder.

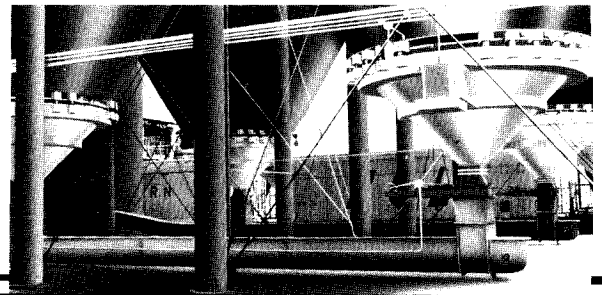

Bin Discharger: 12-ft. in diameter, discharging soybean meal into a screw feeder.

Engineering and Application

Vibranetics Vibrating Bin Dischargers are proven to enhance the flow of bulk materials from storage. With proper engineering application, Vibranetics Bin Dischargers dependably overcome the storage bin problems of classification, ratholing (sometimes referred to as "coring"), and bridging. Many industries handling various granular products such as chemicals, food, coal, ore, filter cake, wood chips, etc., are using Vibranetics Vibrating Bin Dischargers on their bins and silos for higher efficiency and more successful operations.

In order to select and apply the proper Vibrating Bin Discharger to meet the job requirement, it's imperative to understand the basic concepts and problems involved with flow patterns in discharging difficult-to-handle materials from storage. Once these characteristics are known and understood, the user can readily understand why a Vibranetics Vibrating Bin Discharger is an efficient and economical method of eliminating storage bin discharge problems.

The basic problems in discharging materials from storage bins are:

Classification:

The separation of large particles from fine particles, occurring when the material is placed in the storage bin initially. The larger-mass particles tend to fall to the outside of the bin while the fine particles cluster around the center.

Ratholing

Material discharges from the bin's center first and from the outside walls last. If the material along the outside walls has become too packed or has "set," an open core having approximately the diameter of the bin's outlet is formed in the center of the bin, leaving the outside walls packed solid and unflowable.

Bridging

Material forms a structurally bonded arch over the storage bin's outlet. When material is placed in a storage bin, the material exerts static pressure in all directions. With certain materials, this static pressure will contribute to the formation of structural bonds in the material and cause bridging. If no bridging occurs, however, and the material begins

to flow from the bin, the static pressure becomes a dynamic pressure, and may increase the forces of the initial static pressure up to three times. See Figure 1.

The dynamic pressure is created by the flow stream characteristics of the material within the bin. Most bins only provide plug flow, which is a condition when material flows directly in a vertical channel above the bin's outlet with the flow stream diameter determined by the outlet size and shape. A circular outlet will create a flow stream equal to its diameter, and a rectangular outlet will create a flow stream approximately equal to the diagonal of the rectangle. If the material is not free flowing or if the bin's outlet is too small, the material may not slough into the flow stream, and a rathole will form.

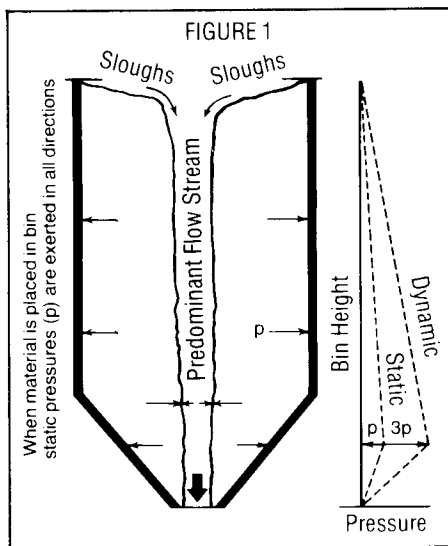

While material is discharging from a bin under a plug flow situation, the material around the sides of the bin remains dormant until the level drops and allows this material to slough into the predominant flow stream. In this dormant state, the material continues to exert pressure to move into the flow stream. Under this dynamic pressure condition, the material may go into compression, locking the particles together in increasing structural strength. Often the dynamic pressure may become so great that the

material will support itself and form a solid rathole. Also, under these conditions, the material can gain sufficient structural strength to form an impenetrable bridge over the bin outlet, especially when the outlet diameter is small.

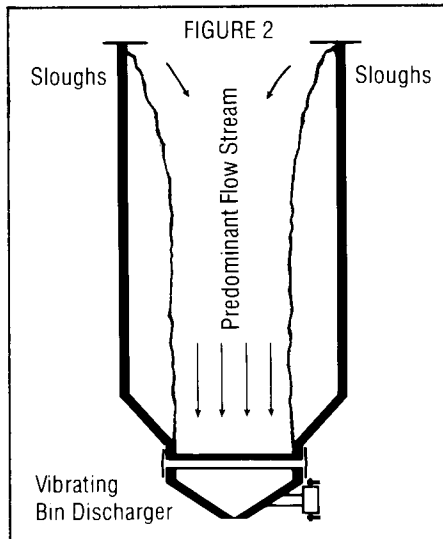

Figure 2 shows the resulting flow stream created when a bin discharger having an inlet diameter smaller than the storage bin diameter is applied to a bin. The predominant flow stream is now enlarged to the inlet diameter of the Vibrating Bin Discharger, causing material to continually slough from the top of the bin into the flow stream and give complete discharge. Bridging and ratholing are reduced because the new flow stream size does not allow the material to become compacted due to the dynamic pressure.

The proper application of a Bin Discharger is most critical if the desired flow is to be obtained, particularly with the more difficult materials. The items of major importance are:

- The inlet and outlet diameter of the discharger must be sufficiently large to permit the material to flow.
- Experience has shown that cyclic operation of the Bin Discharger is more beneficial in inducing material flow than continuous operation.
- Operation of the Bin Discharger when the outlet is restricted can cause serious compaction problems.

The Bin Discharger should be electrically interlocked with downstream equipment (feeder, gate, etc.). This is to insure that the Bin Discharger does not operate without the downstream equipment providing the proper removal of material.

- The primary function of a discharger is to cause material flow. It is *not* a metering device. Metering can be accomplished by any type of feeder, such as vibrating, screw, gravimetric, or belt. It can also discharge directly into a truck or rail car.

Cycling The Flow

For most applications it is advantageous to "cycle" the operation of a Vibrating Bin Discharger. A typical cycling operation involves energizing the discharger for three seconds each minute. Normally, the cycle time is adjusted during initial start-up to provide optimum material flow for specific conditions. An adjustable timer can be supplied with Vibranetics Bin Dischargers. Cycling is particularly advantageous for applications in which the material discharge rate is very small and the job involves storing large volumes of material. Continuous vibration will aggravate the dormant layers and may cause the material to pack on low take-away rate applications.

The greatest advantage of cycling is that the momentary vibrations induce tensile stresses in the material, both along the side walls or in the bin's center, and cause it to collapse and slough into the predominant flow stream.

The Vibranetics Standard Bin Discharger utilizes large horizontal forces to create an elliptical motion. This motion provides a shear action to the materials within the discharger, breaking up any interlocking or compacted materials. The same motion creates a mass inertia effect that moves the material through the outlet on demand. In addition, vibrations are transmitted to the material in the upper bin, providing steady, uninterrupted flow under almost all conditions.

Designed to operate with just a single motor, the Vibranetics Standard Bin Discharger offers the optimum combination of effectiveness, efficiency, economy, and ease of maintenance.

The Vibranetics Drive - Simple, Quiet, Efficient

The drive on the Vibranetics Bin Discharger is one of the simplest, quietest drives available today. It consists of easily adjustable eccentric weights mounted on a large-diameter shaft, which is supported between heavy-duty, self-aligning, double row spherical roller bearings. The shaft is belt driven from a standard foot-mounted motor with a cast-iron frame. Motor enclosures are available as totally enclosed, fan cooled and explosion proof Class I, Group D; Class II, Groups E, F, and G, with Voltages of 220, 440, and 575. Normal lubrication and maintenance are all that is ever required.

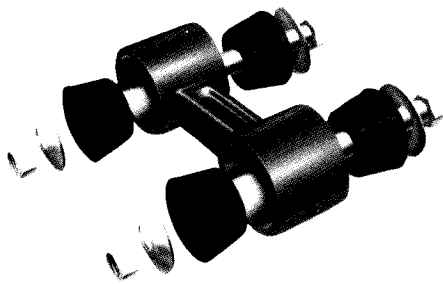

Suspension System - Forged Steel

The suspension system for Vibranetics Bin Dischargers uses forged steel hanger arms with four press fit rubber bushings that isolate the surrounding structure from most of the vibrating forces. Each bushing is retained by an exclusive cup washer that maintains the shape of the bushing and prevents creep.

Eccentric Weights

Vibrating forces in a Vibranetics Bin Discharger are generated by rotating eccentric weights. This assembly consists of two pie-shaped weights, one keyed to the shaft, and the second clamped to the shaft. The second weight can be rotated with respect to the first weight to produce an infinitely adjustable range of forces.

These weights are factory preset and seldom require further adjustment.

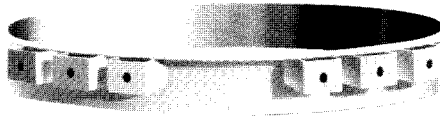

Adapter Ring

Adapter rings are used to mount the Vibranetics Bin Discharger to the bin or hopper. Two types are available. One design is welded directly to the bin or hopper. The other is bolted to a flange on the bin or hopper. (Match-marked companion flange can also be provided.)

Pressure Cone

All Vibranetics Bin Dischargers are equipped with an internal pressure cone. This cone is the heart of the discharger. It is specifically designed to transmit the vibrating energy necessary to induce material flow. The type and dimensions of the cone are determined by the characteristics of the material and other parameters. Vibranetics' engineering staff determines the cone dimensions, based on material tests and hundreds of successful field installations that handle a variety of materials.

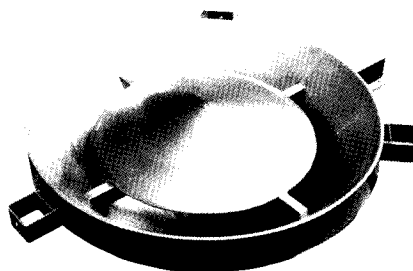

Outer Cone

The standard 45° outer cone is constructed of carbon steel plate and reinforced with stiffening angles to provide structural rigidity and the free flow of material. This cone can be lined with an abrasion-resistant material, stainless steel, or it can be constructed entirely of these materials. The cone angle can also be varied for special applications and unusually difficult materials or service conditions.

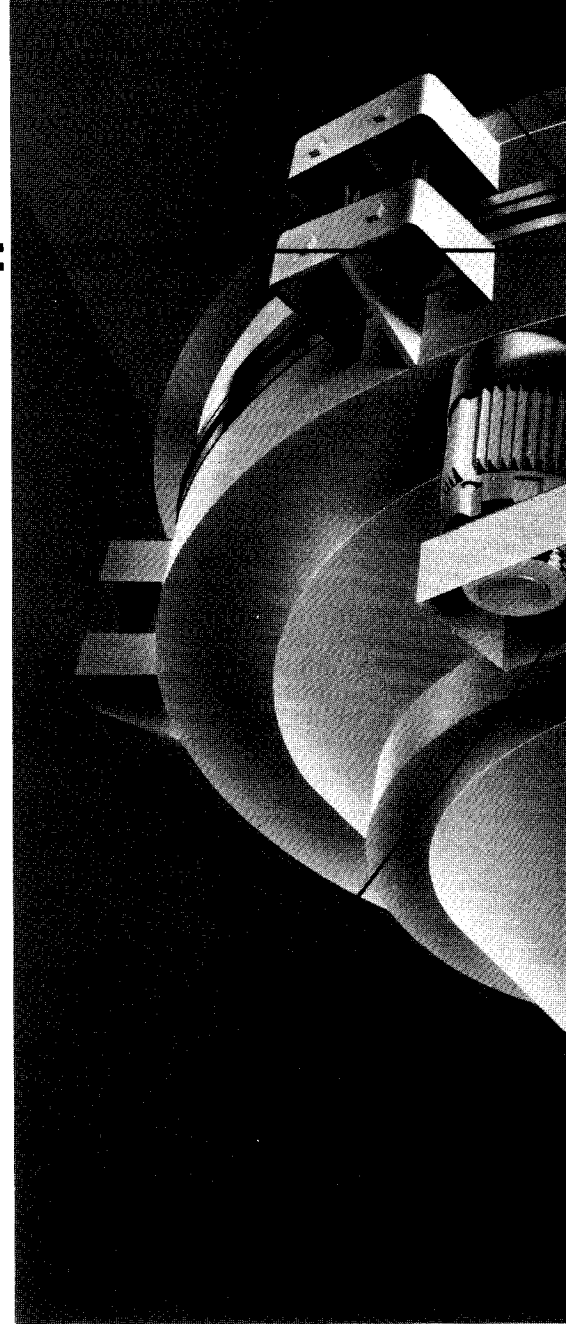



Timer

Vibranetics Bin Dischargers are generally used with repeat cycle timers. The timer is a solid-state device, adjustable for a multitude of cycle ranges, from a few seconds to hours. These timers are frequently interfaced with starve switches at the outlet to provide optimum material flow, especially where the material characteristics change over a wide range.

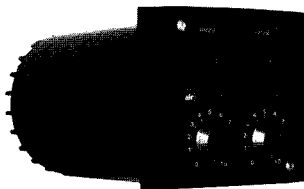

Inlet Seals

Inlet seals provide a flexible, sealed connection between the bin or hopper and the Vibranetics Bin Discharger. Vibranetics inlet seals are available in two styles: The two-piece Double Seal with a separate inlet skirt, Figure 1, and the standard one-piece Super Seal with a built-in skirt, Figure 2. Vibranetics inlet seals of black neoprene are extruded with a convex bulge to aid installation and to provide extra flexibility, thus insuring a long life. Molded-in lips allow drawbands to hold the skirt securely in place, without danger of slippage.

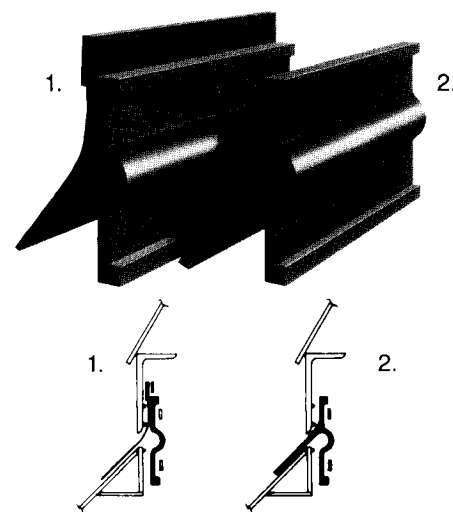

Special designs for high temperature, high pressure or vacuum service are also available. In food grade or other sanitary applications, it is suggested that inlet socks of white neoprene and separate inlet skirts of cord-reinforced white neoprene be used. For fine powder materials, the sock and skirt are vulcanized to the exact diameter of the discharger inlet.

Silicon inlet socks and skirts will be available for high temperature applications to approximately 400°F. For higher temperatures, consult the factory.

Stainless steel bead rings, welded on the adapter ring and discharger, are located strategically to work in conjunction with the drawbands in locking the inlet seal in place and keeping it tight and leak-resistant.

Specifying A Bin Discharger

Many factors enter into the selection of the proper size discharger.

Some are:

- Bin Diameter
- Height of Bin Cylinder
- Hopper Angle
- Product to be Handled
- Particle Size of Product
- Moisture Content of Product
- Internal Friction Angle
- Flow Velocity
- Type of Feeder/Absence of Feeder

Most products can be classified into one of four groups:

- "Adhesive/Interlocking" — such as: paper pulp, brewers grain/wood chips and plastic flake.
- "Sluggish/Floodable" — such as: filter cake, bran, fly ash and calcium carbonate.
- "Average" — such as: limestone and coal.
- "Semi-Free Flowing" — such as: pebble lime, grain and dry clean sand.

Vibranetics generally recommends discharger sizes as outlined below, but specific conditions may dictate variances from these generalities.

Adhesive/Interlocking Products

Full-size dischargers on bins up through 15-feet in diameter. For larger bins, please consult Vibranetics' engineering department for the best application.

Sluggish/Floodable Products

Bin dischargers that are $\frac{2}{3}$ the diameter of the bin.

Average Product

Bin dischargers $\frac{1}{2}$ the diameter of the bin.

Semi-Free Flowing Products

Bin dischargers that are $\frac{1}{3}$ the diameter of the bin.

The above generalizations apply to bins with straight wall height no greater than twice the bin diameter, and a 60° hopper slope. Alterations in either variable can effect the diameter of the discharger required.

Discharge Rate

The discharge rate is not usually a function of the discharger size. The outlet diameter, the feeder at the outlet and material characteristics basically determine the rate of material discharge.

The minimum outlet diameter based on flow conditions is:

$$D = 80 \sqrt{\frac{R}{BV}}$$

Where D = Outlet Diameter, inches

R = Desired Flow rate, tons per hour.

B = Material Bulk Density, pounds per cubic foot.

V = Material flow velocity, feet per minute. (velocities generally vary from 10 to 150 fpm)

Vibranetics Heavy-Duty Bin Dischargers

Optional features available include:

- Special voltages/frequencies
- Explosion proof motors
- Abrasion Resistant Steel or Stainless Steel construction
- Ceramic brick liner
- Sanitary construction
- Specialized epoxy finishes
- Cycle timer
- Outlets available in virtually any configuration
- Vibranetics can also provide a broad spectrum of custom designs, such as eccentric dischargers with offset outlets, or multiple outlets. Bin dischargers can also be specially designed for pressure or vacuum service. In vacuum service applications, special bumpers are installed to restrain the discharger and prevent it from lifting and pinching the inlet skirt. Extra heavy, reinforced socks are available for extreme pressure or vacuum situations.
- Vibranetics offers a variety of slide gate configurations.

Vibranetics Heavy-Duty Bin Dischargers

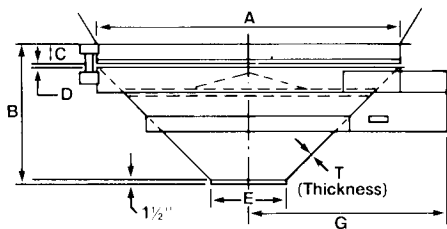

BD-2 THRU BD-8

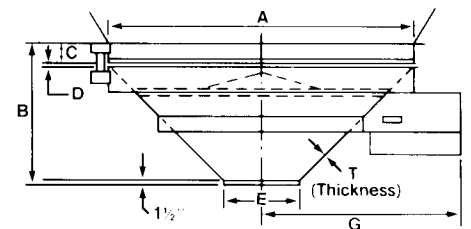
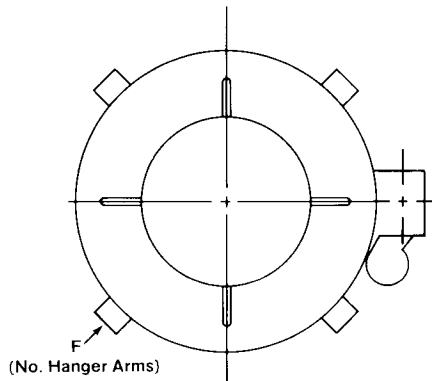

BD-10 THRU BD-15

Dimensions and specifications are approximate and not to be used for construction.

A	2'	3'	4'	5'	6'	7'	8'	10'	12'	15'
*B	1'-11 1/4"	2'-2 1/4"	2'-4 1/4"	2'-11 1/4"	3'-4 1/4"	3'-9 1/4"	4'-2 1/4"	5'-0 1/4"	5'-10 1/4"	7'-3 3/4"
C	6"	6"	6"	6"	8"	8"	8"	8"	8"	8"
D	3/4"	3/4"	3/4"	3/4"	3/4"	3/4"	3/4"	3/4"	3/4"	3/4"
*E (Nom.)	6"	6"	8"	10"	1'-0"	1'-2"	1'-4"	1'-8"	2'-0"	2'-6"
E (Max.)	1'-0"	1'-2"	1'-2"	2'-0"	2'-0"	3'-0"	4'-0"	5'-6"	6'-6"	8'-0"
**F (Min.)	3	3	3	4	3	3	4	8	12	24
G	1'-9 1/2"	2'-4"	2'-11"	3'-5 1/2"	3'-11 1/2"	4'-6 1/2"	5'-2 1/2"	6'-3 1/2"	7'-6"	8'-11 1/4"
T	11 GA	11 GA	11 GA	7 GA	1/4"	1/4"	1/4"	5/16"	5/16"	3/8"
Horsepower	1	1	2	3	5	5	5	7.5	10	10+
Approx. Weight (Pounds)	370	500	760	1110	1880	2375	3380	5500	8900	18500
Approx. Volume (FT. ³)	2.5	5.8	8.3	16	28	45	67	130	225	440

*For Every Inch Added To "E," Subtract 1/2" From "B."

**Number Of Hanger Arms Will Vary With Material Density.

+ Heavy Duty 3-Phase Electric Excitor Motor

Auxiliary And Special Equipment Packages

Frequently, customers ask Vibranetics to supply auxiliary equipment for their vibrating bin dischargers. We can supply a complete pre-engineered package suited to the customer's needs — for example, a complete material handling system that includes a bin, a pneumatic fill line, pressure-vacuum manhole, bin vent filter, OSHA caged ladder, level indicators, bin discharger and feeder. The package is completely unitized and can be shipped to the jobsite assembled and ready for use.

Vibranetics engineers can also assist in the selection of feeding equipment below the discharger outlet. Screw feeders and vibrating feeders manufactured by Vibranetics are specifically designed for use with bin dischargers.

For complete information on how Vibranetics can help you with your material handling problems, contact us or your local factory-trained Vibranetics representative.

Live Bottom Bins

A convenient variation of the Vibranetics Bin Discharger is the Live Bottom Bin. This pre-engineered, pre-assembled unit is particularly suited for new or expanded facilities. Live Bottom Bins are available in a wide range of standard sizes, appropriate for most requirements (see listing below). Custom sizes are also available.

The standard live bottom bin consists of a cylindrical tank that is fitted with a full-size Vibranetics Bin Discharger. The "Super Seal" is used to seal the discharger to the bin. Other seals are available on request. The drive unit is the same as that used on the standard Vibranetics Bin Discharger. The bin can be supplied with a support structure on request.

Available options are same as for Bin Discharger.

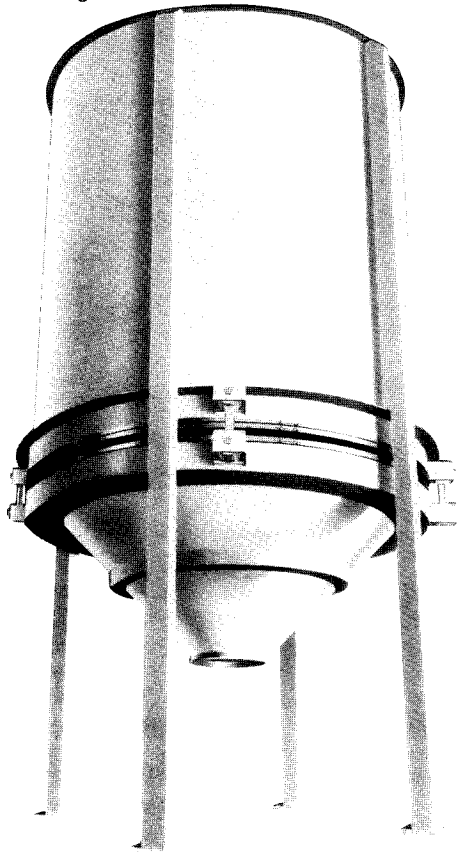

Vibrating Live Bins

Another variation of the vibrating bin discharger is the Vibrating Live Bin. The entire unit vibrates rather than just the discharger at the bottom. These units are completely pre-engineered and pre-assembled and are available in a wide range of standard sizes, as well as custom designs. Unlike the Live Bottom Bin, the discharger is built directly into the tank, with no flexible connection between them.

This one-piece unit is capable of meeting stringent sanitary conditions or high toxicity conditions where the flexible connection might prove a source of contamination or leakage.

To prevent vibrations from being transferred from the bin to the supporting structure or building, Vibranetics Live Bins are isolation-mounted on their support columns by means of an elastomer that permits free movement of the bin in both the vertical and horizontal planes, yet eliminates most of the vibration that might be transmitted through the columns. Vibranetics Live Bins are normally supplied with the same heavy-duty drive unit as the Live Bottom Bins.

Available options are same as for Bin Discharger.

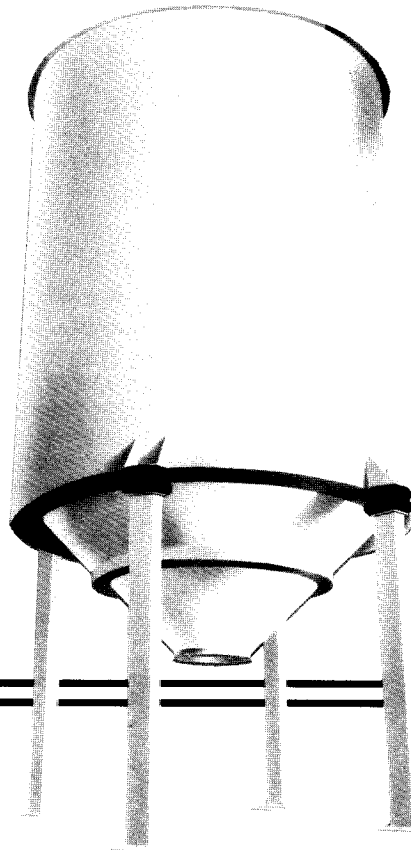

Live Bottom Bins

Dimensions and specifications are approximate and not to be used for construction.

Model	A	B	C	D	E	G	T	Vol. (Cu. Ft.)	Min. No. Hanger Arms	Wgt. (Lb.)	H.P.
LBH-2-8	2'-0"	1'-5½"	2'-0"	6'-0¼"	4"	1'-9½"	11 GA.	8	4	581	1.0
LBH-2-15	2'-0"	1'-5½"	4'-0"	8'-0¼"	4"	1'-9½"	11 GA.	15	4	665	1.0
LBH-3-25	3'-0"	1'-7½"	3'-0"	7'-2¼"	6"	2'-4"	11 GA.	25	4	857	1.0
LBH-3-50	3'-0"	1'-7½"	6'-0"	10'-2¼"	6"	2'-4"	11 GA.	50	4	1029	1.0
LBH-4-50	4'-0"	1'-9½"	3'-6"	7'-10¼"	8"	2'-11"	11 GA.	50	4	1207	2.0
LBH-4-75	4'-0"	1'-9½"	5'-6"	9'-10¼"	8"	2'-11"	11 GA.	75	4	1373	2.0
LBH-4-100	4'-0"	1'-9½"	7'-6"	11'-10¼"	8"	2'-11"	11 GA.	100	4	1498	2.0
LBH-5-100	5'-0"	2'-2½"	4'-6"	9'-3¼"	10"	3'-5½"	7 GA.	100	4	2222	3.0
LBH-5-150	5'-0"	2'-2½"	7'-0"	11'-9¼"	10"	3'-5½"	7 GA.	150	4	2567	3.0
LBH-5-200	5'-0"	2'-2½"	9'-6"	14'-3¼"	10"	3'-5½"	7 GA.	200	4	2861	3.0
LBH-6-200	6'-0"	2'-7½"	6'-3"	11'-5¼"	1'-0"	3'-11½"	¼"	200	4	3431	5.0
LBH-6-250	6'-0"	2'-7½"	8'-0"	13'-2¼"	1'-0"	3'-11½"	¼"	250	4	3687	5.0
LBH-6-300	6'-0"	2'-7½"	9'-9"	14'-11¾"	1'-0"	3'-11½"	¼"	300	4	3934	5.0
LBH-7-300	7'-0"	3'-0½"	7'-0"	12'-7¼"	1'-2"	4'-6½"	¼"	300	4	4534	5.0
LBH-7-350	7'-0"	3'-0½"	8'-3"	13'-10¼"	1'-2"	4'-6½"	¼"	350	4	4740	5.0
LBH-7-400	7'-0"	3'-0½"	9'-6"	15'-1¼"	1'-2"	4'-6½"	¼"	400	4	4946	5.0
LBH-8-400	8'-0"	3'-5½"	7'-0"	13'-0¼"	1'-4"	5'-2½"	¼"	400	4	6266	5.0
LBH-8-500	8'-0"	3'-5½"	9'-0"	15'-0¼"	1'-4"	5'-2½"	¼"	500	4	6779	5.0
LBH-10-800	10'-0"	4'-3½"	9'-0"	15'-10¼"	1'-8"	6'-3½"	5/16"	800	8	10,226	7.5
LBH-10-900	10'-0"	4'-3½"	10'-0"	16'-10¼"	1'-8"	6'-3½"	5/16"	900	8	10,548	7.5
LBH-12-1000	12'-0"	5'-1½"	7'-0"	14'-8¼"	2'-0"	7'-6"	5/16"	1000	12	13,462	10.0
LBH-12-1200	12'-0"	5'-1½"	8'-6"	16'-2¼"	2'-0"	7'-6"	5/16"	1200	12	14,040	10.0

Live Bottom Bins

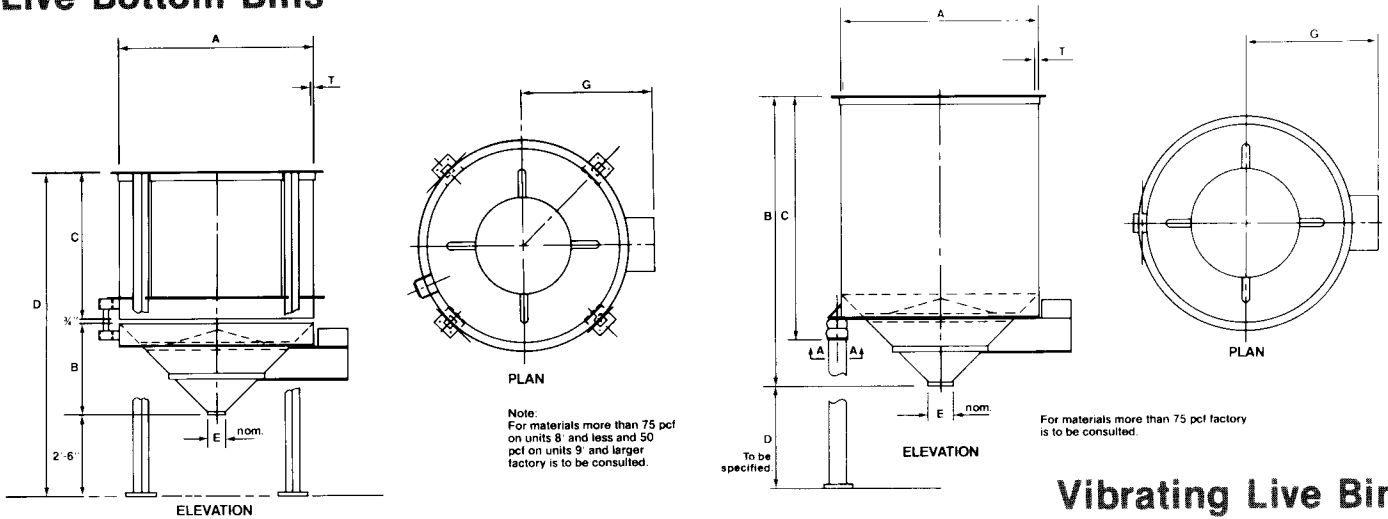

Vibrating Live Bins

Model	A	B*	C*	E	G	T	Vol. (Cu. Ft.)	Min. No. Isolators	Wgt. (Lb.)	H.P.
VB-2-7	2'-0"	2'-9⅞"	2'-9½"	4"	1'-9½"	11 GA.	7	3	390	1.0
VB-3-15	3'-0"	3'-4⅜"	2'-9⅝"	6"	2'-4"	11 GA.	15	3	618	1.0
VB-3-25	3'-0"	4'-10⅜"	4'-3⅝"	6"	2'-4"	11 GA.	25	3	692	1.0
VB-4-50	4'-0"	5'-3⅜"	4'-7½"	8"	2'-11"	11 GA.	50	3	931	2.0
VB-5-75	5'-0"	5'-8⅜"	4'-7⅝"	10"	3'-5½"	3/16	75	4	1830	3.0
VB-5-110	5'-0"	7'-2⅜"	6'-1⅝"	10"	3'-5½"	3/16	110	4	2106	3.0
VB-6-200	6'-0"	8'-7¼"	7'-7⅝"	1'-0"	3'-11½"	1/4	200	4	3,267	5.0
VB-7-300	7'-0"	10'-0¼"	8'-7⅝"	1'-2"	4'-6½"	1/4	300	4	4,526	5.0
VB-8-450	8'-0"	11'-5¼"	9'-8"	1'-4"	5'-2½"	1/4	450	8	5,993	5.0
VB-10-900	10'-0"	14'-3¼"	11'-10"	1'-8"	6'-3½"	5/16"	900	8	10,688	7.5
VB-12-1600	12'-0"	17'-1¼"	13'-11¾"	2'-0"	7'-6"	5/16"	1600	12	16,108	10.0

Dimensions and specifications are approximate and not to be used for construction.
 *Dimensions calculated without material in bin. Product weight will decrease these dimensions.

APPLICATION OF VIBRATING STORAGE PILE DISCHARGERS

Storage piles are an economical arrangement for storage of large quantities of bulk solids. However, some materials such as limestone, coal, woodchips, sulphur, etc. need assistance in flowing from a storage pile.

BASIC PROBLEMS

Only a small portion of the volume is withdrawable because the material "cores" directly to the top of the pile, with this core opening being the total reclaimable "live" storage. Increasing the "live" area relates to the basis problem of vertical flow patterns of the specific type of materials.

(FIG.1) The vertical core or channel reflects the configuration of the opening in the ground or tunnel below: this "favored or predominant vertical flow stream" in all cases will be circular. If openings are square or rectangular, the diameter of the stream will be equal their diagonal. The volume of withdrawable material is projected by determining the stored material's "internal friction angle B". Measured from the horizontal, this is the angle at which the material will slide down upon itself; it is generally greater than the material's "natural angle of repose A". In most cases, the internal friction angle is at least 60°. For difficult materials this may be as much as 90°. As the predominant vertical flow stream drops its top level, the pile will continue to dump inward from the upper layers into this stream in the form of "sloughs" flowing in expanding concentric circles until the material's internal friction angle is met. This is the total "live" storage or withdrawal available from the pile.

VIBRANETICS ANSWERS

Vibranetics Storage Pile Dischargers are used successfully to provide more "live" storage area, providing advantages over all other systems. They are engineered to produce a predominant vertical flow stream of predictable diameter to:

- withdraw uniformly and concentrically
- maintain constant command of the top layer sloughs

(FIG.1) A Vibranetics Vibrating Storage Pile Discharger is installed under a typical outdoor storage pile with three drawdown outlets. Through controlled vibrating action that induces the pile to flow, this system operates on a "cycle" basis with relatively small energy consumption. The vibrating cycle of a few seconds each minute is adjusted to assure continuous flow, while eliminating packing of dormant material.

A heavy steel "drawdown skirt" - triangular in cross-section and sloped at a 45° angle - is attached to the discharger inlet above ground level. This maintains constant vibratory contact with the storage pile, thereby transmitting impulses from bottom to top. This Vibranetics system will normally produce a drawdown angle approximately 5° greater than the material's "natural angle of repose", thus increasing "live" storage and eliminating flow-stoppage problems.

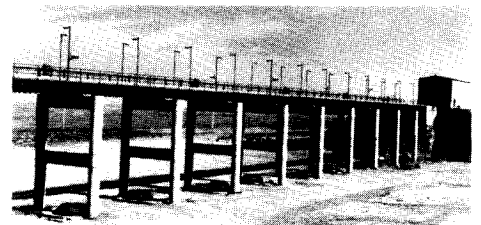
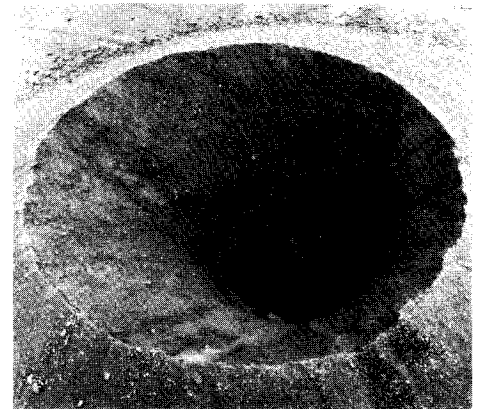
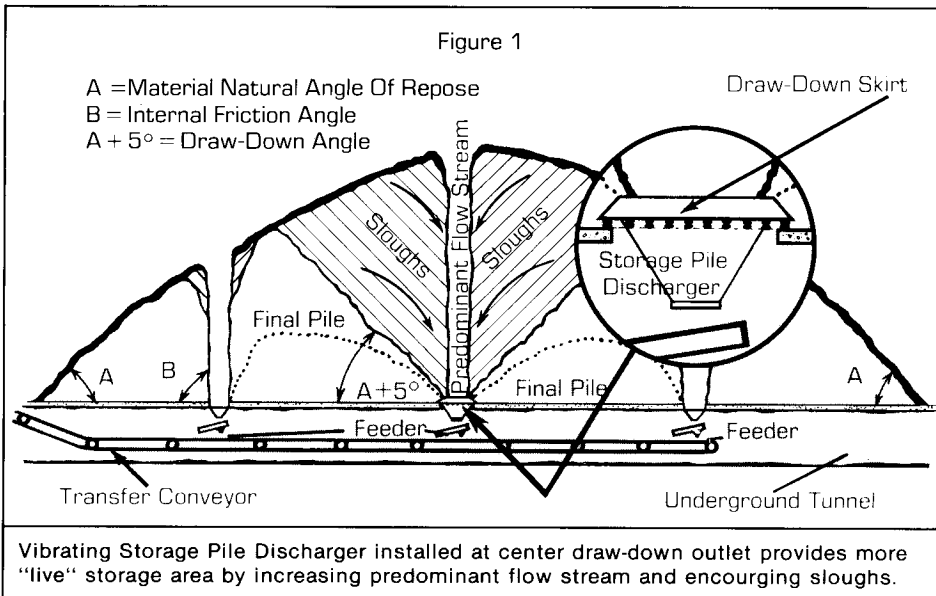

ATTEMPTED SOLUTIONS

Enlarged ground openings increase flow stream, but require a feeder underneath to control rate of flow to a transfer conveyer, (FIG.2) An apron or belt feeder tends to "favor feed" from its back end. The front end becomes a dormant area which backs up into the storage pile and reduces the size of flow stream. (FIG.3) Vibrating feeder will "favor feed" from its forward end, resulting in dormant area in back end, again reducing the effective size of the flow stream.

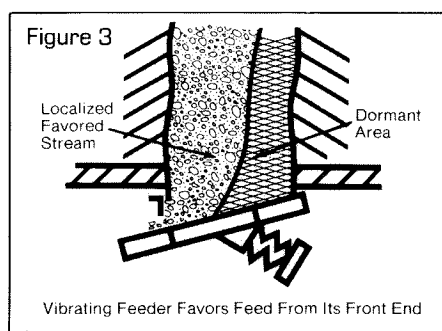
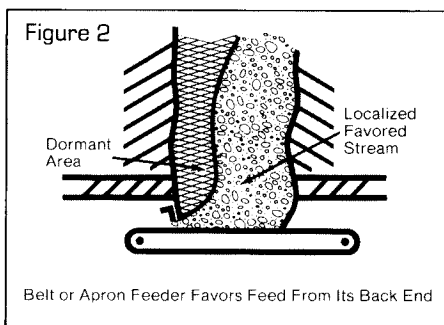

VERSATILE AND DEPENDABLE

Vibranetics Pile Dischargers can be adapted to any existing installation such as flat bottom bins, stacking towers; conical, longitudinal and kidney-shaped piles. Designed to suit requirements, these systems are proven performers in a wide range of industrial applications.

STORAGE PILE DISCHARGER DIMENSIONS

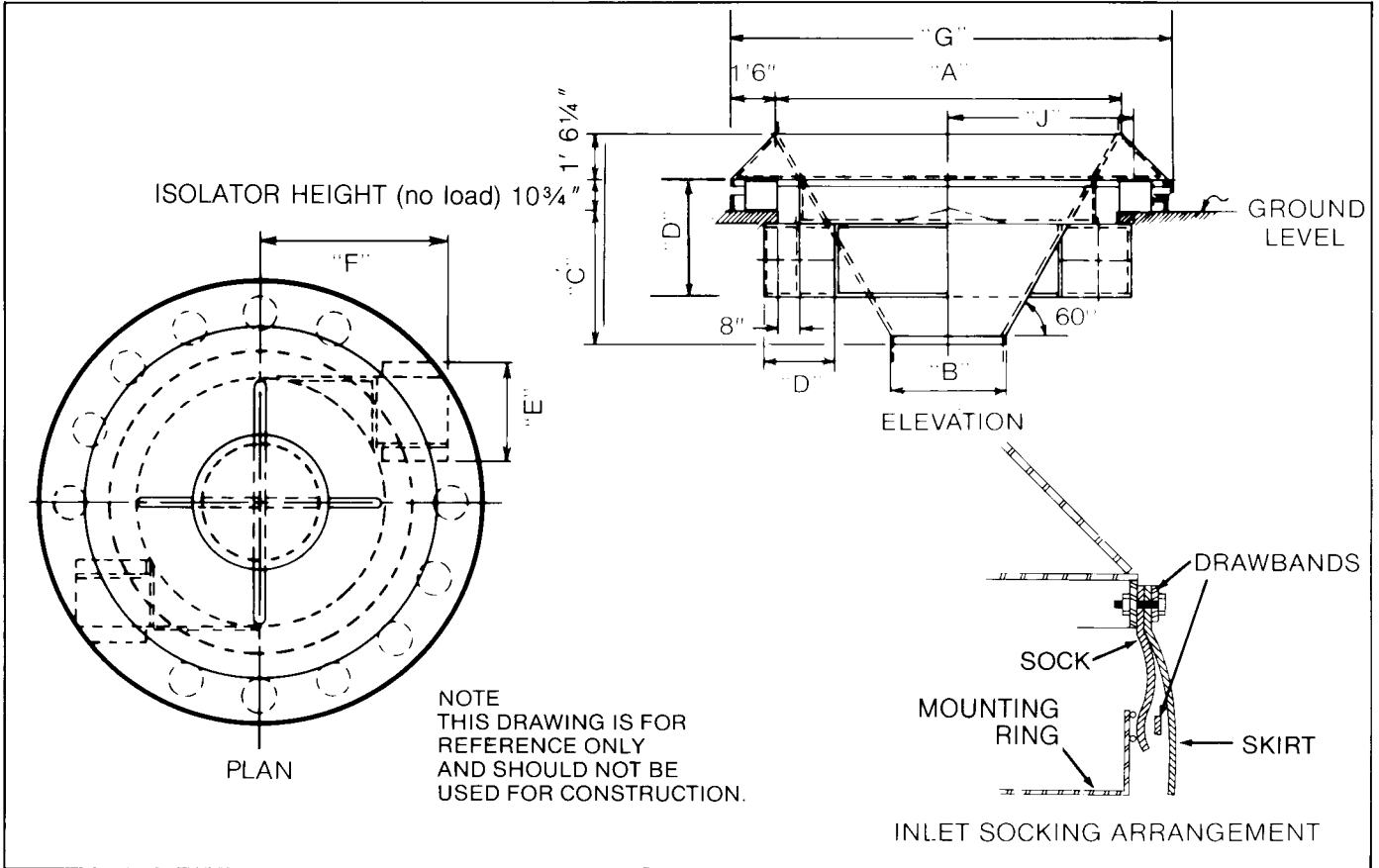

Model	Vol. FT ³	Total H.P. (TENV.)	A	B	C	D	E	F	G	J	T	Wgt.	Exciter Force Output
SPD-11	106	4	96	42	24	23 ³ / ₄	23 ³ / ₈	47 ¹ / ₄	132	53	5 ⁵ / ₁₆	9890 lbs.	26,000 lbs.
SPD-13	212	10	120	48	34 ¹ / ₄	30	32 ¹ / ₂	56 ³ / ₈	156	65	3 ³ / ₈	15060 lbs.	40,000 lbs.
SPD-15	378	20	144	48	43	43 ¹ / ₂	36 ³ / ₁₆	69 ³ / ₁₆	180	77	3 ³ / ₈	17375 lbs.	80,000 lbs.

Specifications Subject To Change Without Notice

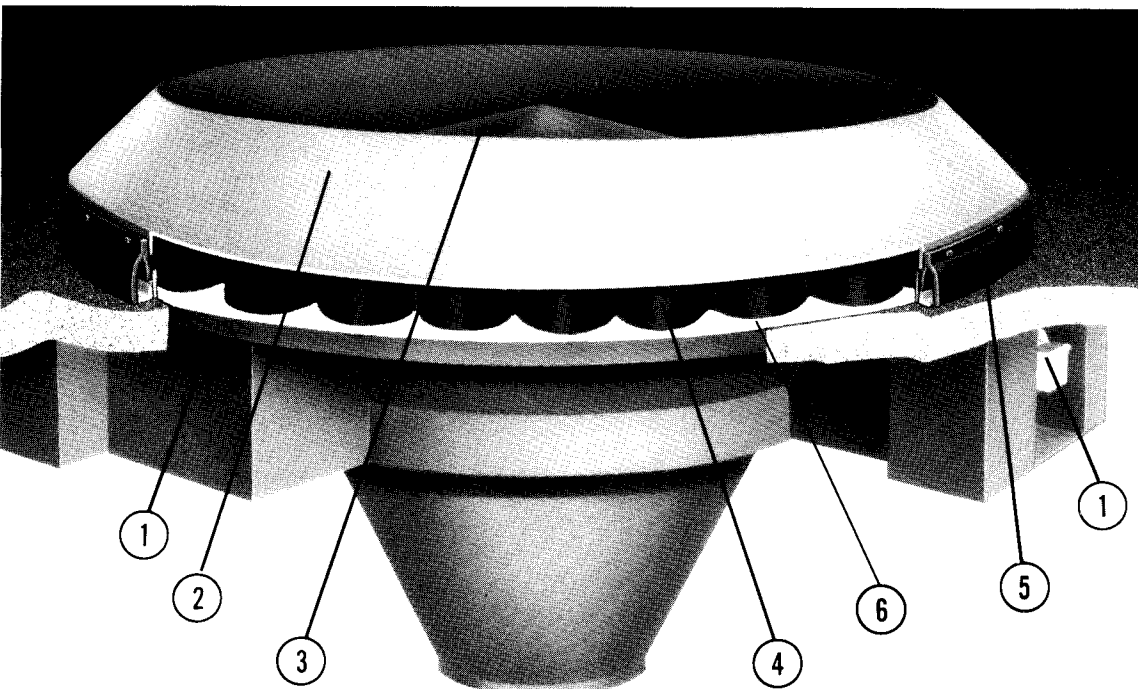

- ① ELECTRIC EXCITER MOTORS
- ② DRAW DOWN SKIRT
- ③ INTERNAL PRESSURE CONE
- ④ RUBBER ISOLATORS
- ⑤ SOCK & SKIRT ASSEMBLY
- ⑥ ISOLATOR MOUNTING RING



Vibrating Equipment, Inc.

AND  **Vibranetics® Division**

THE STANDARD OF EXCELLENCE IN BULK MATERIAL HANDLING AND PROCESSING EQUIPMENT

Fluid Bed Dryer/Cooler Systems, Conveyors, Spiral Elevators, Feeders, Shakeouts
Screens, Bin Activators, Pile Dischargers

CARRIER VIBRATING EQUIPMENT, INC. and VIBRANETICS DIVISION of CARRIER
3400 Fern Valley Road • P. O. Box 37070 • Louisville, Kentucky 40233 • (502) 969-3171 • FAX: (502) 969-3172
www.carriervibrating.com • e-mail: cve@carriervibrating.com

CARRIER Vibrating Equipment (CANADA) Ltd. • Aurora, Ont. • (905) 727-3185 • FAX: (905) 727-3187

CARRIER Europe, SCA • Nivelles, Belgium • 32-67-883-753 • FAX: 32-67-883-688

Representation: USA, CANADA, MEXICO, KOREA, P.R. CHINA, TAIWAN

Licensees: India, Japan, Sweden

Reproduction or transmission of all or any part of the information contained herein is unauthorized without the written consent of Carrier Vibrating Equipment, Inc. UNAUTHORIZED DUPLICATION OR REPRODUCTION OF THIS INFORMATION IS A VIOLATION OF FEDERAL LAW.